

Karakteristikler



- Büyük endüstriyel kap?lar için yatay veya dikey monte edilebilen yüksek performanslı hava perdesi.1.5 2.0 2.5 3. ve 3.5 metre uzunlu?unda mevcuttur.Büyük boyutlara eri?mek için kolay kenetlenen modüller.
- A??r, kendini ta??yan, inko kaplamalı elikten yap?lm?? kasa, standart olarak yap?sal epoksi-polyester RAL9016 beyaz boyayla cilalan?r.Di?er renkler iste?e tabiidir.
- Daha fazla ve verimli hava ak?m? için Coanda etkili çift ?k?? .Anodize edilmi? alüminyum priz pervaneleri, kanat ?eklinde, iki tarafta da 0'dan 15°'e kadar ayarlanabilir.
- Yüksek verimli ve dü?ük sesli aksel fanlar, tek fazlı d??tan 230V rotor motoru taraf?ndan hareket ettirilir. Opsiyonel olarak üç fazlı 400V. Bak?m gerektirmez. EC modelleri dü?ük tüketimli verimli fanlar içerir.
- "P" tipi su ile ?s?t?lan bobin."E" tipi elektrik korumalı elementler, birle?ik ayarlı üç evre."A" tipi ?s?tmas?z, sadece hava ile.
- Regulation not included. Optional: Advanced PRO control with LCD display and integrated thermostat, door contact, 10m RJ11 cable and remote control. Intelligent Clever Pro Control (automatic, programmable, ModBus for PKC, timer, etc.)

Ki?iselle?tirme

50Hz

Model	Is?nmam??	
	(m ³ /h)	(m)
MXW 1500 A 400Vx3	4-6	
MXW 1500 A 400Vx3 W/R	4-6	
MXW 2000 A 400Vx3 W/R	4-6	
MXW 2000 A 400Vx3	4-6	
MXW 2500 A 400Vx3 W/R	4-6	
MXW 2500 A 400Vx3	4-6	
MXW 3000 A 400Vx3	4-6	
MXW 3000 A 400Vx3 W/R	4-6	
MXW 3500 A 400Vx3	4-6	
MXW 3500 A 400Vx3 W/R	4-6	
MXW 1500 A W/R	4-6	
MXW 1500 A	4-6	
MXW 2000 A	4-6	
MXW 2000 A W/R	4-6	
MXW 2500 A W/R	4-6	
MXW 2500 A	4-6	
MXW 3000 A W/R	4-6	
MXW 3000 A	4-6	
MXW 3500 A W/R	4-6	
MXW 3500 A	4-6	
MXW EC 1500 A W/R	6-8	
MXW EC 2000 A W/R	6-8	
MXW EC 2500 A W/R	6-8	
MXW EC 3000 A W/R	6-8	
MXW EC 3500 A W/R	6-8	

Elektrikli Is?tma



Model	(m ³ /h)	(kW)	(m)
MXW 1500 E 400Vx3 W/R	4-6		
MXW 2000 E 400Vx3 W/R	4-6		
MXW 2500 E 400Vx3 W/R	4-6		
MXW 3000 E 400Vx3 W/R	4-6		
MXW 3500 E 400Vx3 W/R	4-6		
MXW 1500 E W/R	4-6		
MXW 2000 E W/R	4-6		
MXW 2500 E W/R	4-6		
MXW 3000 E W/R	4-6		
MXW 3500 E W/R	4-6		
MXW EC 1500 E W/R	6-8		
MXW EC 2000 E W/R	6-8		
MXW EC 2500 E W/R	6-8		
MXW EC 3000 E W/R	6-8		
MXW EC 3500 E W/R	6-8		

Su Isıtma			
Model	(m ³ /h)	(m)	(kW)
MXW 1500 P86 400Vx3 W/R	-		
MXW 1500 P86 400Vx3	-		
MXW 2000 P86 400Vx3	-		
MXW 2000 P86 400Vx3 W/R	-		
MXW 2500 P86 400Vx3	-		
MXW 2500 P86 400Vx3 W/R	-		
MXW 3000 P86 400Vx3 W/R	-		
MXW 3000 P86 400Vx3	-		
MXW 3500 P86 400Vx3 W/R	-		
MXW 3500 P86 400Vx3	-		
MXW 1500 P86	-		
MXW 1500 P86 W/R	-		
MXW 2000 P86	-		
MXW 2000 P86 W/R	-		
MXW 2500 P86 W/R	-		
MXW 2500 P86	-		
MXW 3000 P86	-		
MXW 3000 P86 W/R	-		
MXW 3500 P86	-		
MXW 3500 P86 W/R	-		
MXW EC 1500 P86 W/R	-		
MXW EC 2000 P86 W/R	-		
MXW EC 2500 P86 W/R	-		
MXW EC 3000 P86 W/R	-		
MXW EC 3500 P86 W/R	-		
MXW 1500 P64 400Vx3	34.09		
MXW 1500 P64 400Vx3 W/R	34.09		



Model	Su Is?tma			
	(m ³ /h)	(m)	(kW)	(kW)
MXW 2000 P64 400Vx3	50.16			
MXW 2000 P64 400Vx3 W/R	50.16			
MXW 2500 P64 400Vx3 W/R	66.19			
MXW 2500 P64 400Vx3	66.19			
MXW 3000 P64 400Vx3	92.28			
MXW 3000 P64 400Vx3 W/R	92.28			
MXW 3500 P64 400Vx3	97.92			
MXW 3500 P64 400Vx3 W/R	97.92			
MXW 1500 P64	34.09			
MXW 1500 P64 W/R	34,09			
MXW 2000 P64 W/R	50,16			
MXW 2000 P64	50,16			
MXW 2500 P64 W/R	66,19			
MXW 2500 P64	66,19			
MXW 3000 P64 W/R	82,22			
MXW 3000 P64	82,22			
MXW 3500 P64	97,92			
MXW 3500 P64 W/R	97,92			
MXW EC 1500 P64 W/R	39.6			
MXW EC 2000 P64 W/R	58.2			
MXW EC 2500 P64 W/R	75.36			
MXW EC 3000 P64 W/R	92.53			
MXW EC 3500 P64 W/R	110.14			

60Hz

Model	Is?nmam??	
	(m ³ /h)	(m)
MXW L 1500 A 60Hz	4-6	
MXW L 1500 A 60Hz W/R	4-6	
MXW L 2000 A 60Hz	4-6	
MXW L 2000 A 60Hz W/R	4-6	
MXW L 2500 A 60Hz W/R	4-6	
MXW L 2500 A 60Hz	4-6	
MXW L 3000 A 60Hz W/R	4-6	
MXW L 3000 A 60Hz	4-6	
MXW L 3500 A 60Hz	4-6	
MXW L 3500 A 60Hz W/R	4-6	
MXW EC 1500 A W/R	6-8	
MXW EC 2000 A W/R	6-8	
MXW EC 2500 A W/R	6-8	
MXW EC 3000 A W/R	6-8	
MXW EC 3500 A W/R	6-8	

Elektrikli Is?tma



Model	(m ³ /h)	(kW)	(m)
MXW EC 1500 E W/R	6-8		
MXW EC 2000 E W/R	6-8		
MXW EC 2500 E W/R	6-8		
MXW EC 3000 E W/R	6-8		
MXW EC 3500 E W/R	6-8		

Model	(m ³ /h)	Su Is?tma		
		(m)	(kW)	(kW)
MXW EC 1500 P86 W/R	-			
MXW EC 2000 P86 W/R	-			
MXW EC 2500 P86 W/R	-			
MXW EC 3000 P86 W/R	-			
MXW EC 3500 P86 W/R	-			
MXW EC 1500 P64 W/R	39.6			
MXW EC 2000 P64 W/R	58.2			
MXW EC 2500 P64 W/R	75.36			
MXW EC 3000 P64 W/R	92.53			
MXW EC 3500 P64 W/R	110.14			



Boyutlar

Water Heated / Unheated

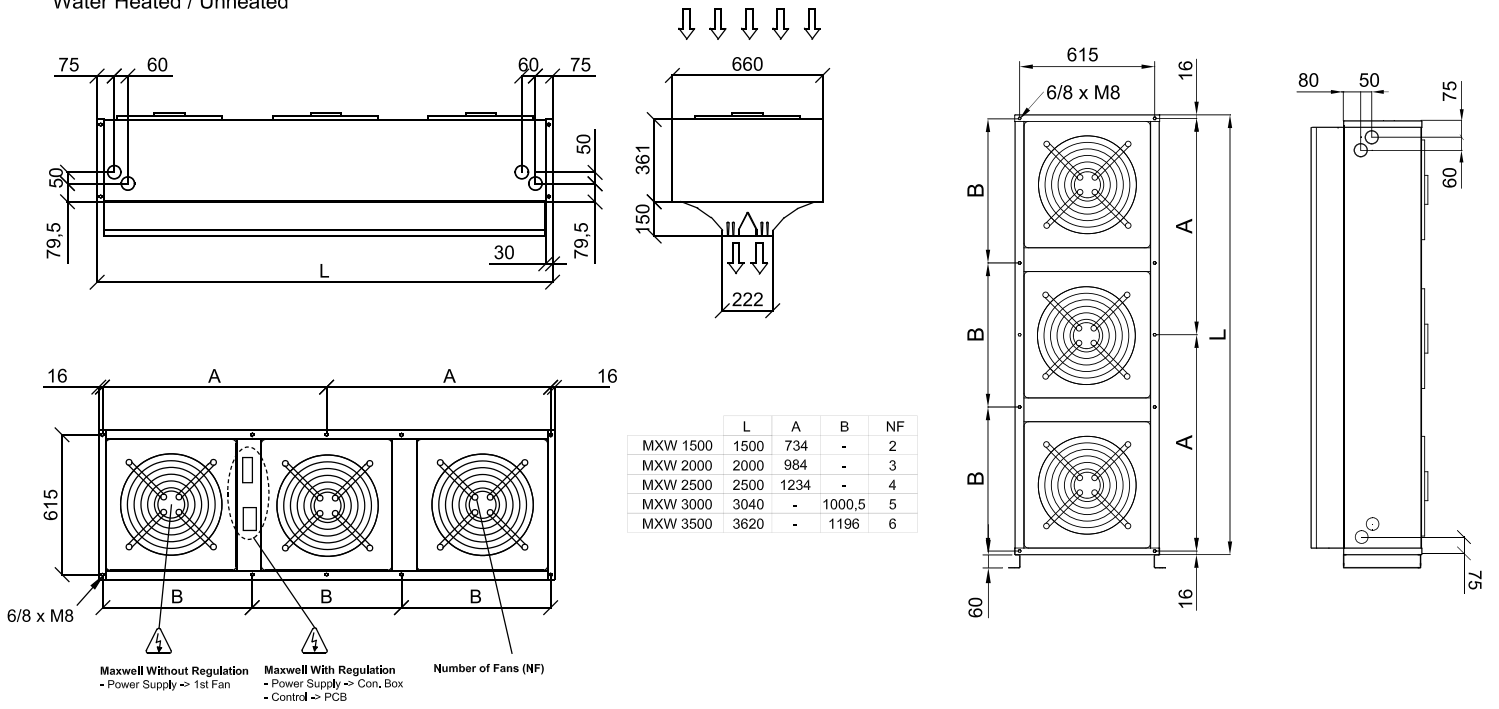

Electrical Heated

